

# PRODUCT SPECIFICATIONS

## WOODLAND BACKLESS BENCH - 48"

Engineered with cross-bolting to prevent end play

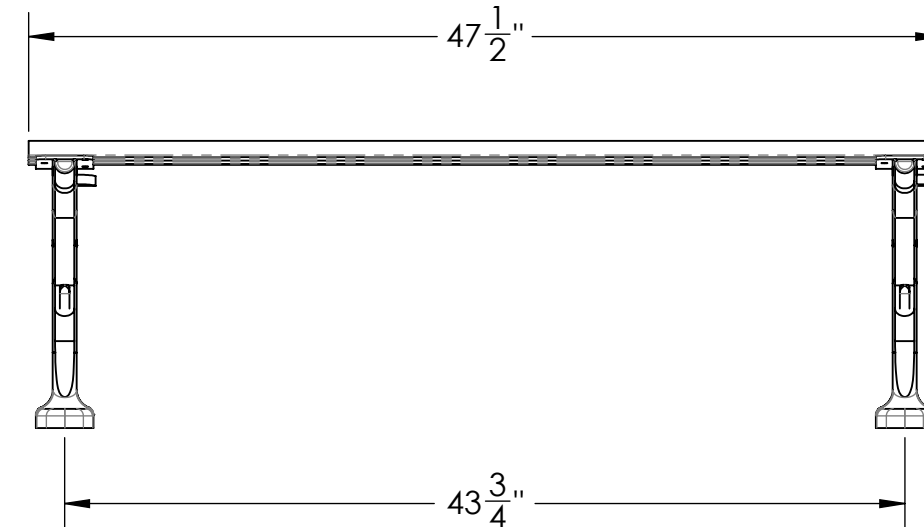
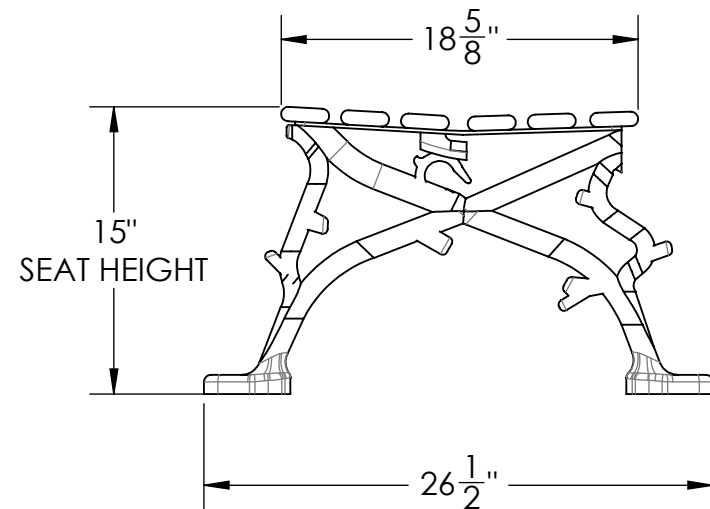
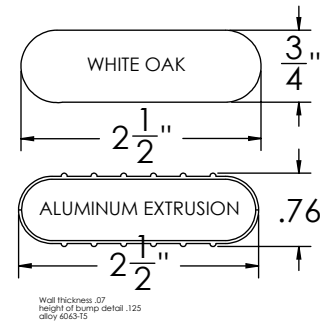
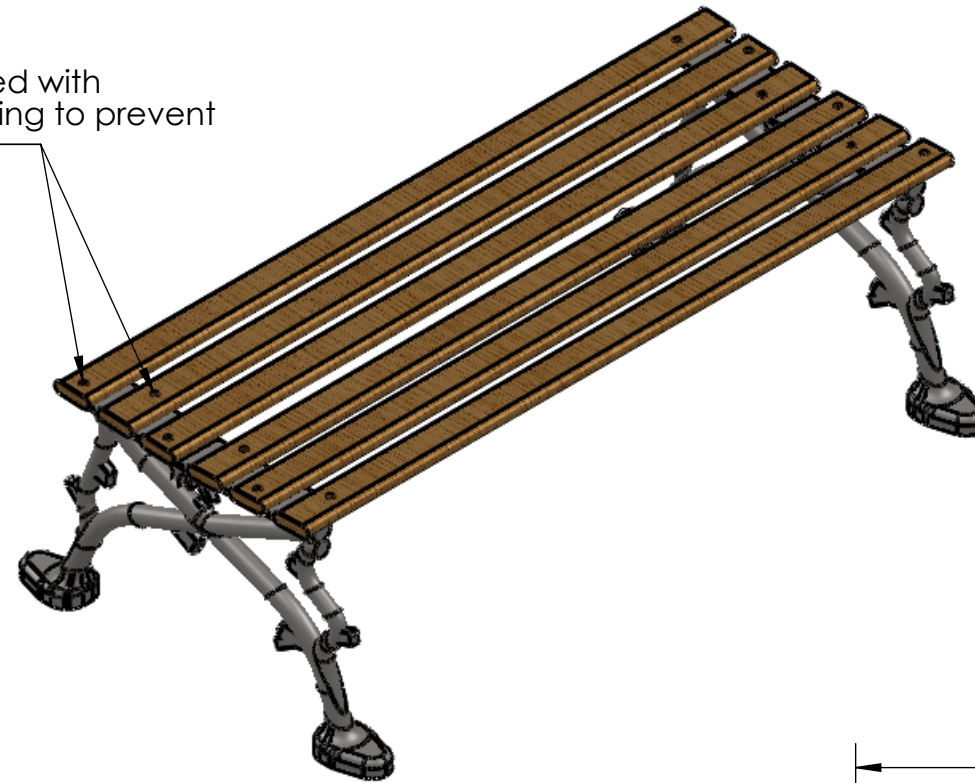

### FRAME

- **Material:** Cast aluminum poured in permanent molds
- **Finish:** Electro static powder coating
- **Color:** Black, White, Green, Tan, Dk. Brown, Dk. Green, Bronze and Blue.

### WOOD RAILS

- **Material:** FAS White Oak
- **Size:** 2 1/2" wide by 3/4" milled two edges 3/4" half round
- **Number of Rails:** 6
- **Finish:** PENOFIN® impact impregnated
- **Maintenance:** Apply PENOFIN® as necessary. Follow manufacture's instructions.

### HARDWARE

- **Carriage Bolts:** 1/4"-20 steel zinc plate, yellow dipped
- **Nuts:** 1/4" steel zinc plate



### DESCRIPTION:

## WOODLAND BACKLESS BENCH - 48"

ADDRESS:  
1350 NORTH AVE.  
SANGER, CALIFORNIA 93657  
PHONE: (559) 875-8250  
FAX: (559) 875-1491  
kingsrivercasting@verizon.net

THE INFORMATION CONTAINED IN THIS DRAWING IS THE SOLE PROPERTY OF KINGS RIVER CASTING. ANY REPRODUCTION IN PART OR WHOLE WITHOUT THE WRITTEN PERMISSION OF KINGS RIVER CASTING IS PROHIBITED.

WEIGHT: 33 LBS

SCALE: 1:10

MODEL NUMBER:

**WBBS - 48"**

SIZE  
B