

PRODUCT SPECIFICATIONS

VICTORIAN BACKLESS BENCH - 80"

Engineered with cross-bolting to prevent end play

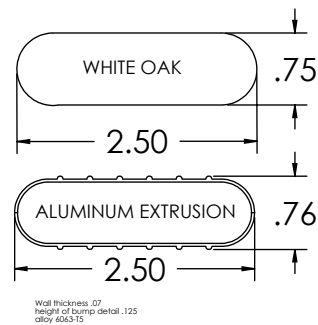
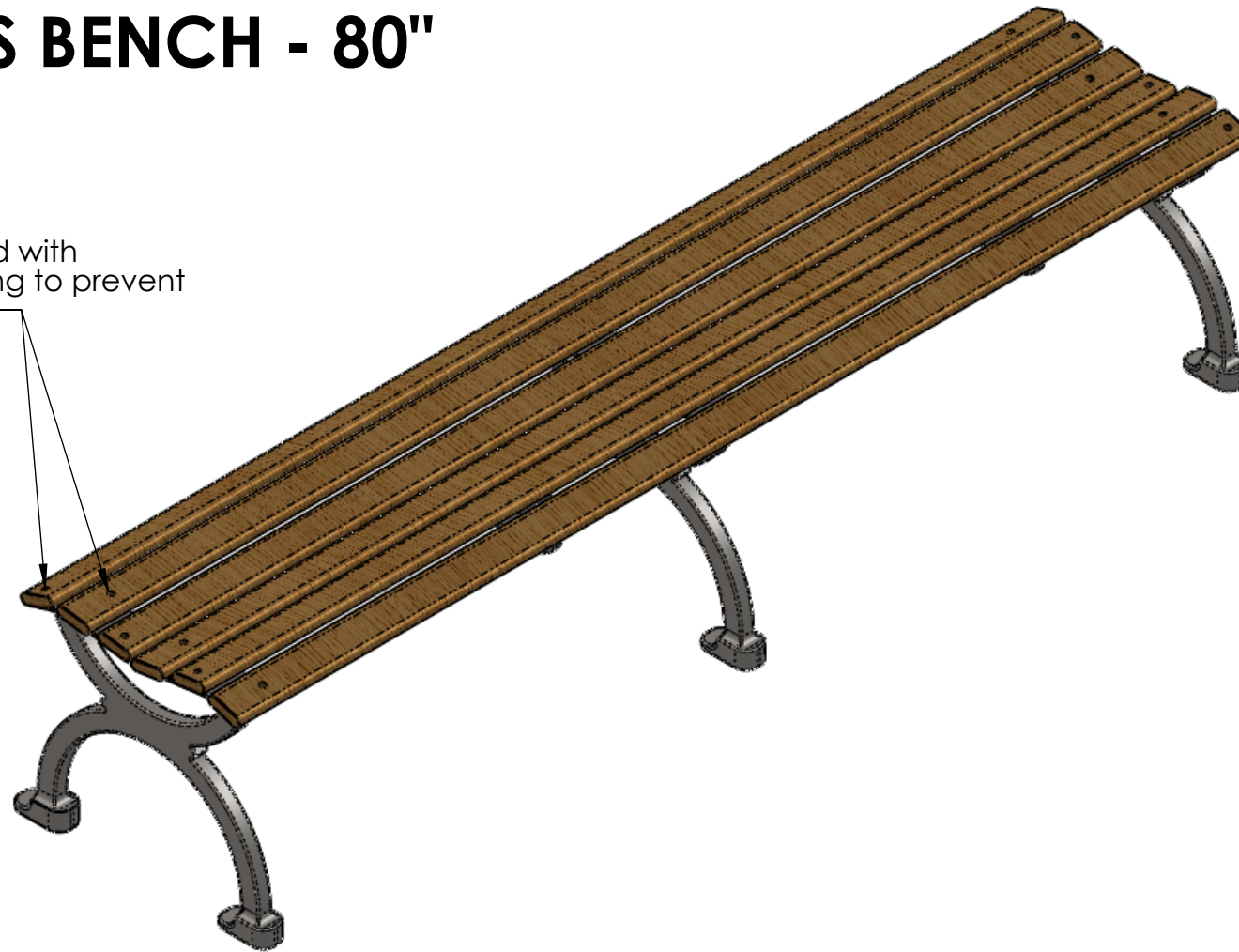

FRAME

- **Material:** Cast aluminum poured in permanent molds
- **Finish:** Electro static powder coating
- **Color:** Black, White, Green, Tan, Dk. Brown, Dk. Green, Bronze and Blue.

WOOD RAILS

- **Material:** FAS White Oak
- **Size:** 2 1/2" wide by 3/4" milled two edges 3/4" half round
- **Number of Rails:** 6
- **Finish:** PENOFIN® impact impregnated
- **Maintenance:** Apply PENOFIN® as necessary. Follow manufacture's instructions.

HARDWARE

- **Carriage Bolts:** 1/4"-20 steel zinc plate, yellow dipped
- **Nuts:** 1/4" steel zinc plate

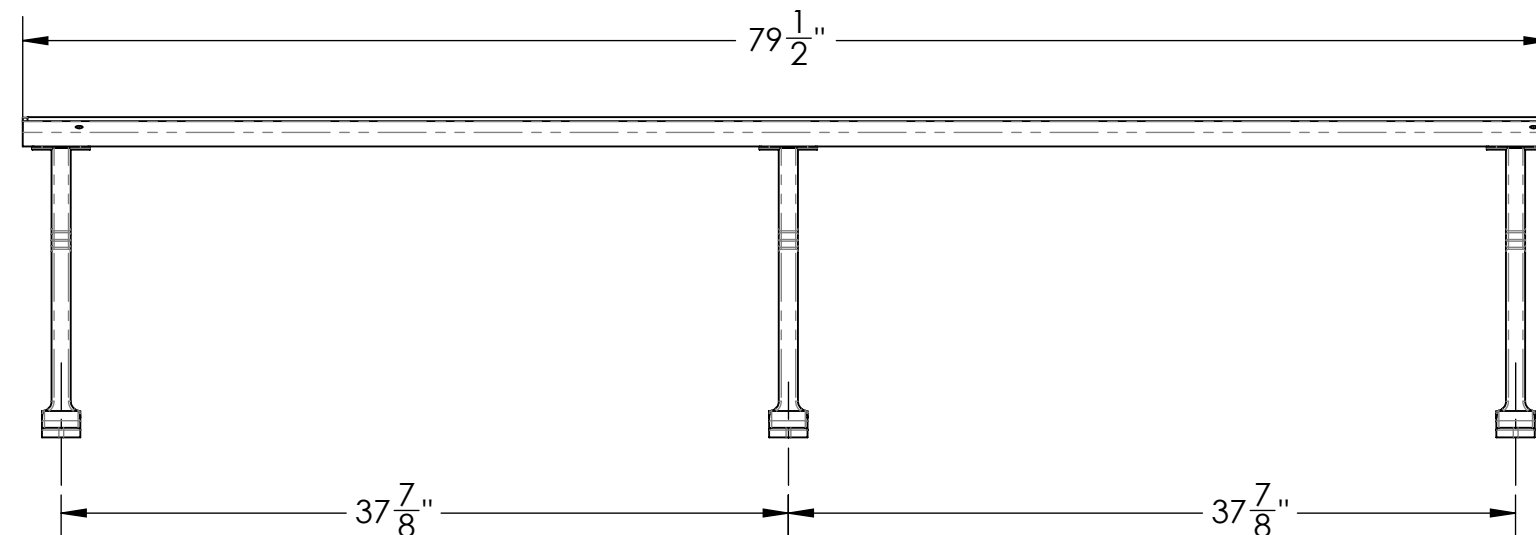
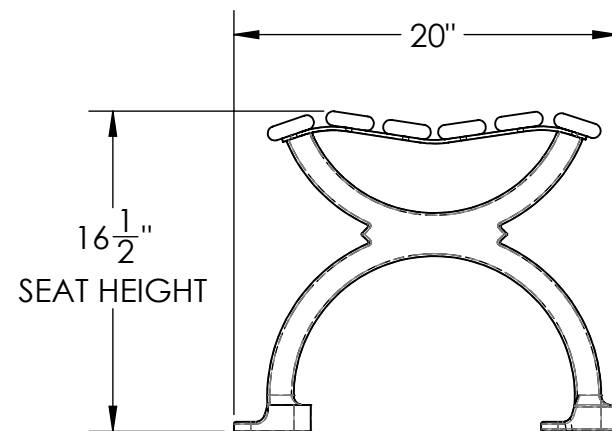

BOLT DOWN DETAIL

VICTORIAN and RENAISSANCE benches can be drilled for permanent attachment.



DESCRIPTION:

VICTORIAN BACKLESS BENCH - 80"

ADDRESS:
1350 NORTH AVE.
SANGER, CALIFORNIA 93657
PHONE: (559) 875-8250
FAX: (559) 875-1491
kingsrivercasting@verizon.net

THE INFORMATION CONTAINED IN THIS DRAWING IS THE SOLE PROPERTY OF KINGS RIVER CASTING. ANY REPRODUCTION IN PART OR WHOLE WITHOUT THE WRITTEN PERMISSION OF KINGS RIVER CASTING IS PROHIBITED.

WEIGHT: 46 LBS

SCALE: 1:10

MODEL NUMBER:

VBBLF - 80"

SIZE

B