

PRODUCT SPECIFICATIONS

TRASH/RECYCLING CONTAINER - TRC

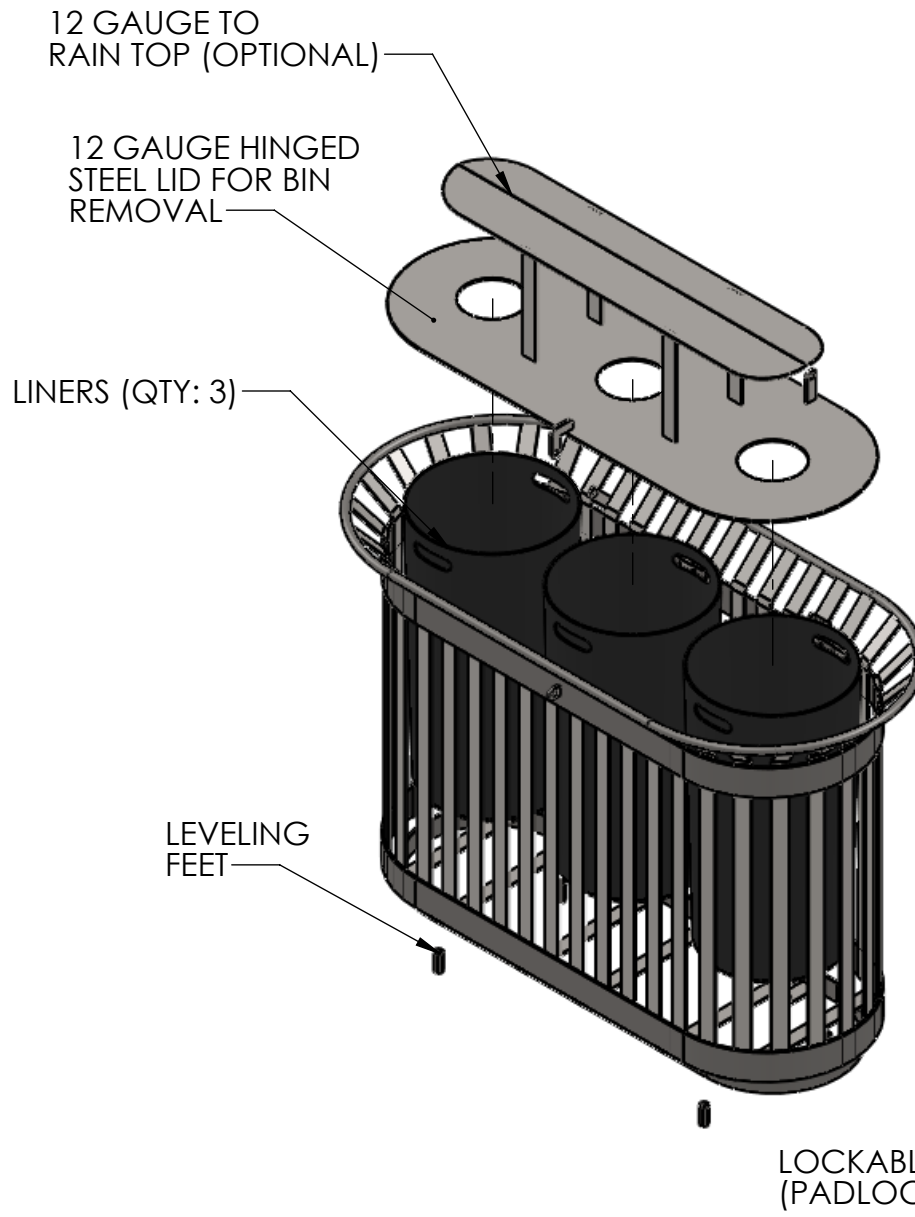
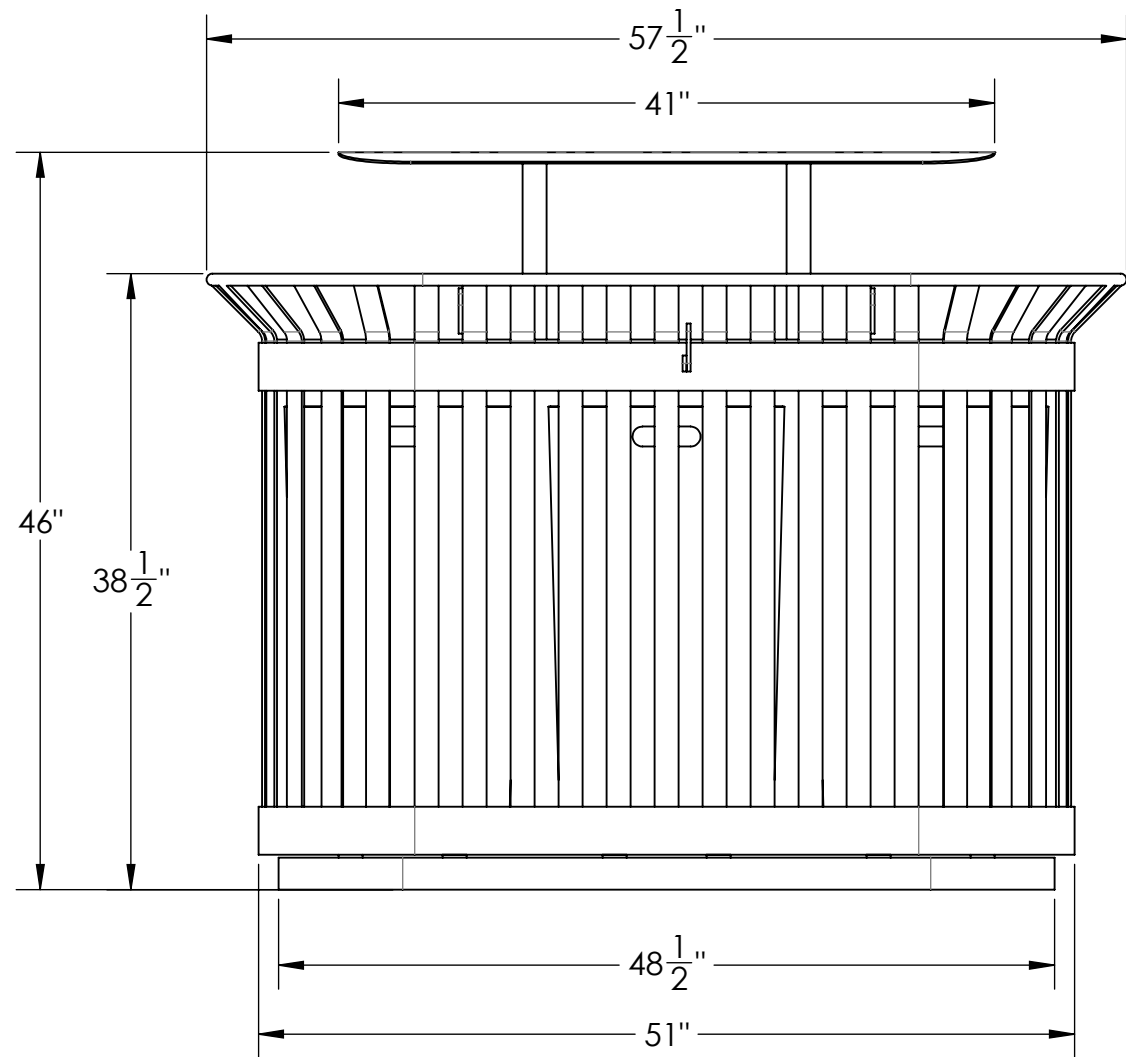
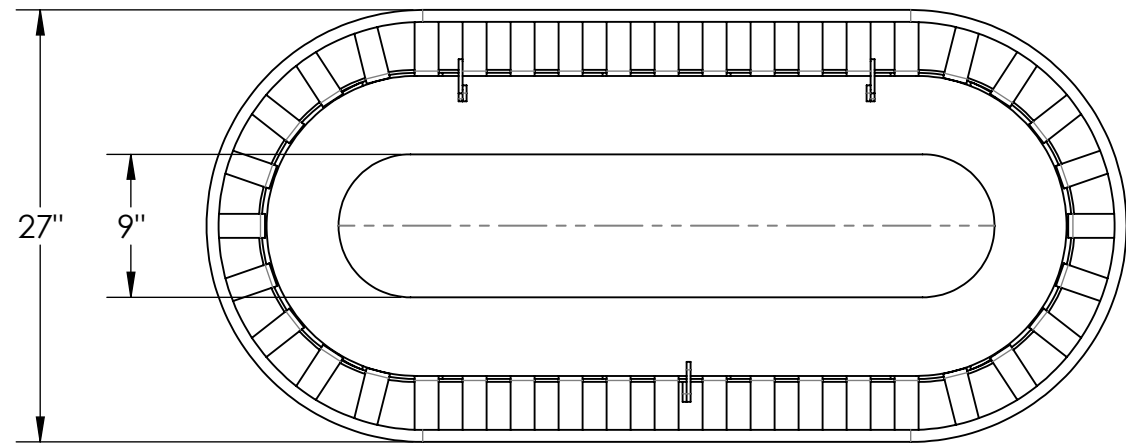

NOTES

THE RECPETACLE COMES FULLY WELDED AND NO ASSEMBLY IS REQUIRED. ANCHORING HARDWARE NOT INLCUDED. DECALS FOR RECYCLING ARE OPTIONAL.

MATERIALS

FRAME:

STEEL BAR SLATS - 1 1/2" X 3/16"
 STEEL BAR HOOPS - 3" X 3/16"
 STEEL BAR BASE - 2" X 3/16"
 STEEL RIM HOOP - 3/4" HOT ROLLED ROUND BAR

LINERS:

LINERS INCLUDED. CAPACITY - 24 GALLONS. LINERS ARE COMMERCIAL GRADE PLASTIC.

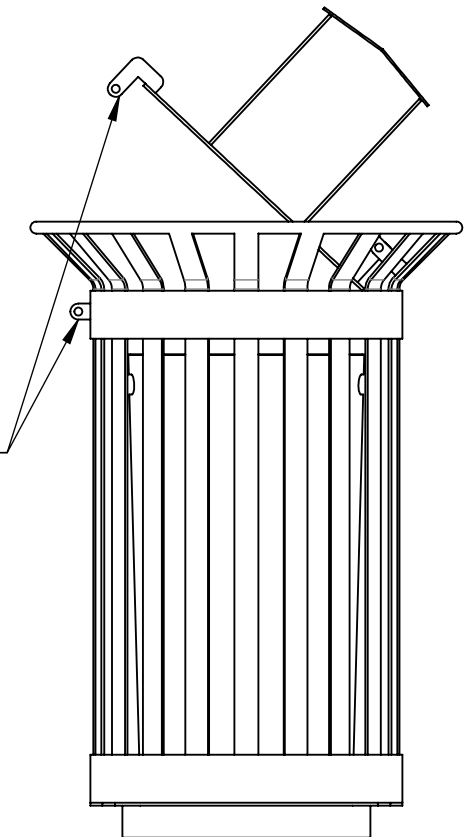

DESCRIPTION:		TRASH/RECYCLING CONTAINER - TRC	
ADDRESS: 1350 NORTH AVE. SANGER, CALIFORNIA 93657 PHONE: (559) 875-8250 FAX: (559) 875-1491 kingsrivercasting@verizon.net	THE INFORMATION CONTAINED IN THIS DRAWING IS THE SOLE PROPERTY OF KINGS RIVER CASTING. ANY REPRODUCTION IN PART OR WHOLE WITHOUT THE WRITTEN PERMISSION OF KINGS RIVER CASTING IS PROHIBITED.	WEIGHT: 263 LBS	SCALE: 1:12
		MODEL NUMBER: TRC	SIZE B