

PRODUCT SPECIFICATIONS

TOWNSHIP TRASH RECEPTACLE

OPTIONS INCLUDE:

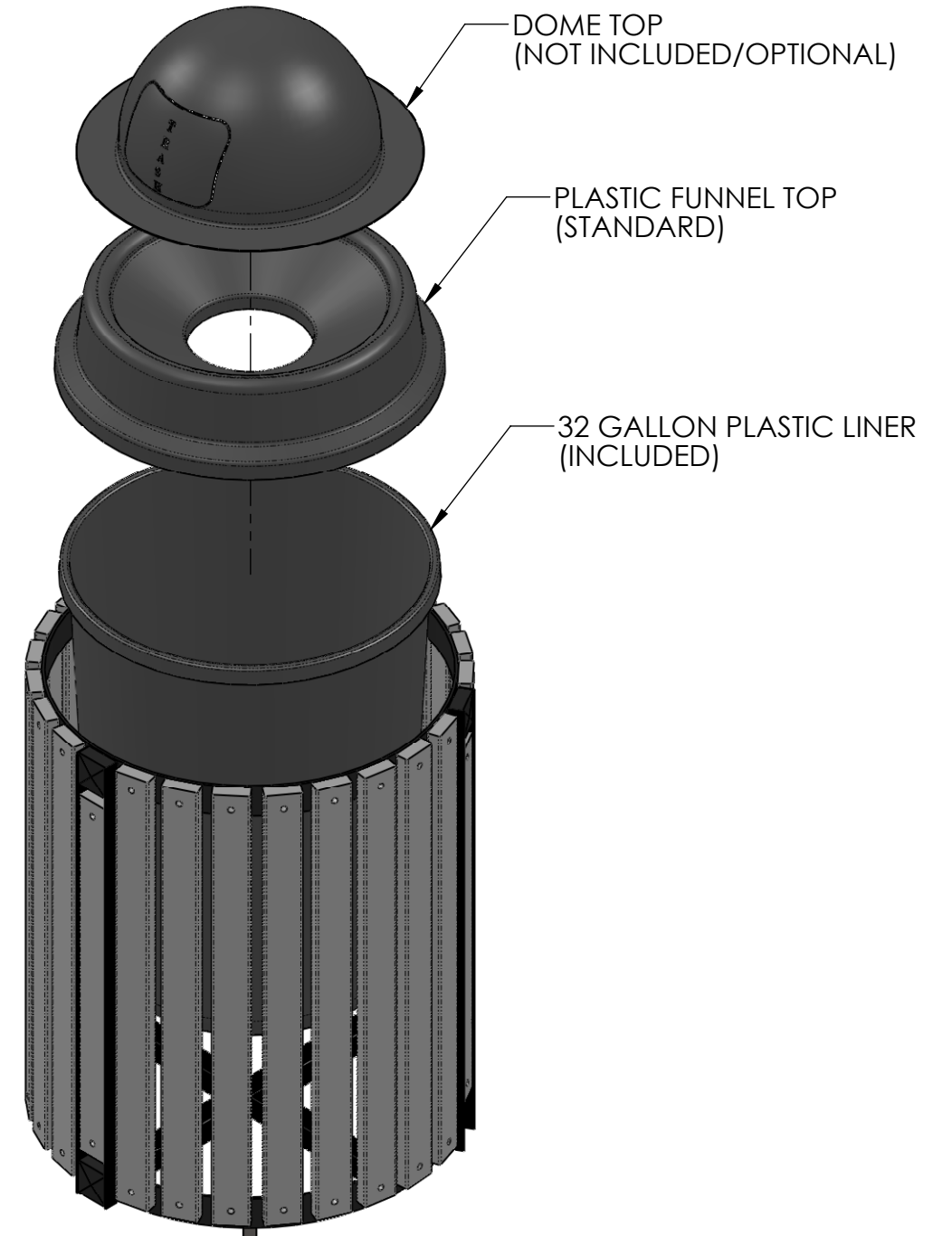
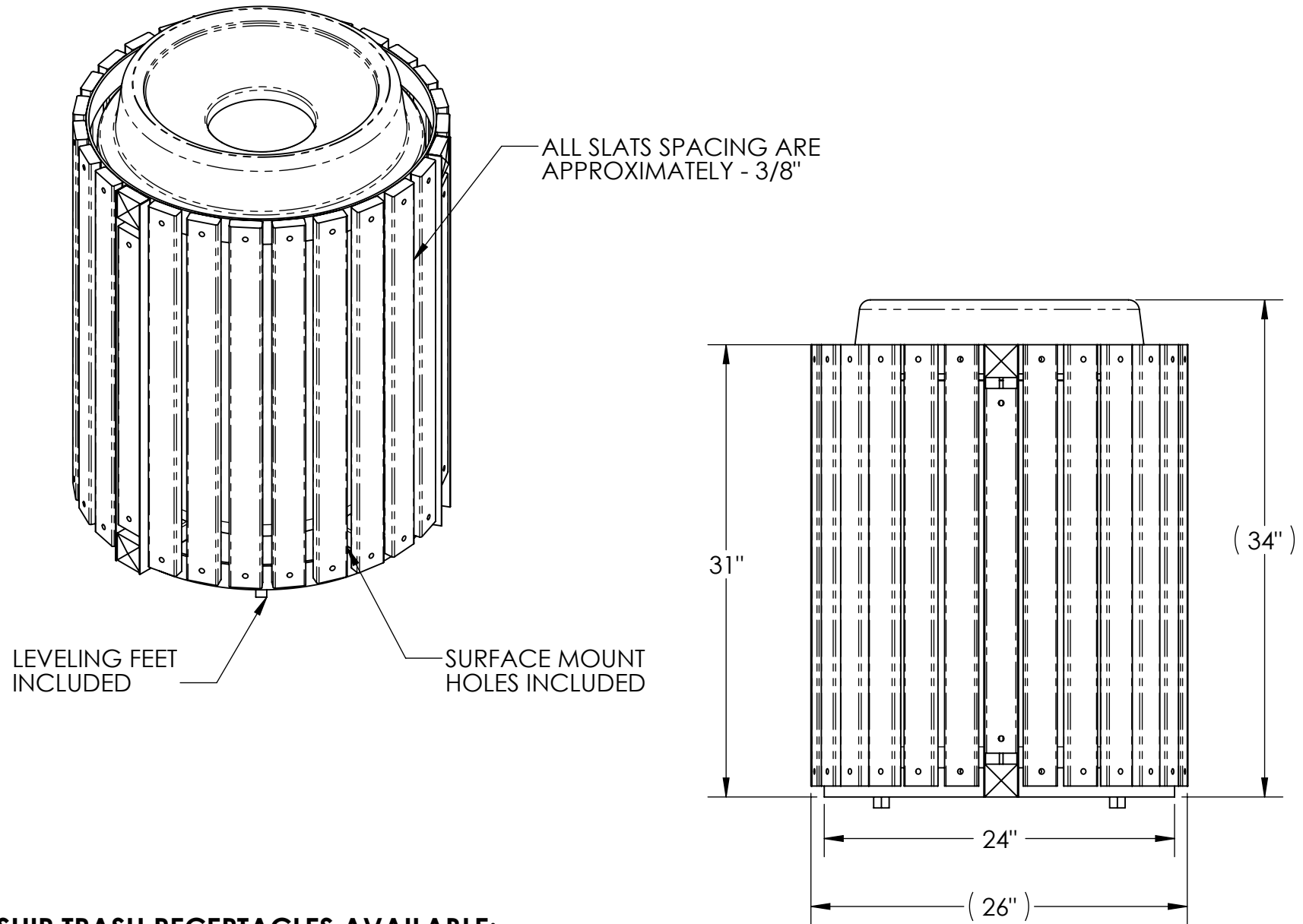

TOWNSHIP TRASH RECEPTACLES AVAILABLE:

DESCRIPTION

TOWNSHIP TRASH RECEPTACLE - OAK
 TOWNSHIP TRASH RECEPTACLE - RECYCLED PASTIC
 TOWNSHIP TRASH RECEPTACLE - ALUMINUM
 TOWNSHIP TRASH RECEPTACLE - FIBERGLASS
 TOWNSHIP TRASH RECEPTACLE - IPE

MODEL NO.

TTR-OAK
 TTP-RP
 TTR-A
 TTR-FG
 TTR-IPE

*PRICES AVAILABLE UPON REQUEST.
 *WEIGHTS VARY UPON MATERIAL USED



DESCRIPTION:

TOWNSHIP TRASH RECEPTACLE

ADDRESS:
 1350 NORTH AVE.
 SANGER, CALIFORNIA 93857
 PHONE: (559) 875-8250
 FAX: (559) 875-1491
 kingsrivercasting@verizon.net

THE INFORMATION CONTAINED IN THIS DRAWING IS THE SOLE PROPERTY OF KINGS RIVER CASTING. ANY REPRODUCTION IN PART OR WHOLE WITHOUT THE WRITTEN PERMISSION OF KINGS RIVER CASTING IS PROHIBITED.

WEIGHT: 90 LBS
 MODEL NUMBER:
TTR

SCALE: 1:10

SIZE
B