

PRODUCT SPECIFICATIONS

RENAISSANCE PARK BENCH - 80"

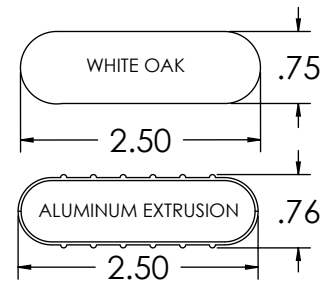

Wall thickness .07
Height of bump detail .125
 alloy 6063 T5

Engineered with cross-bolting to prevent end play

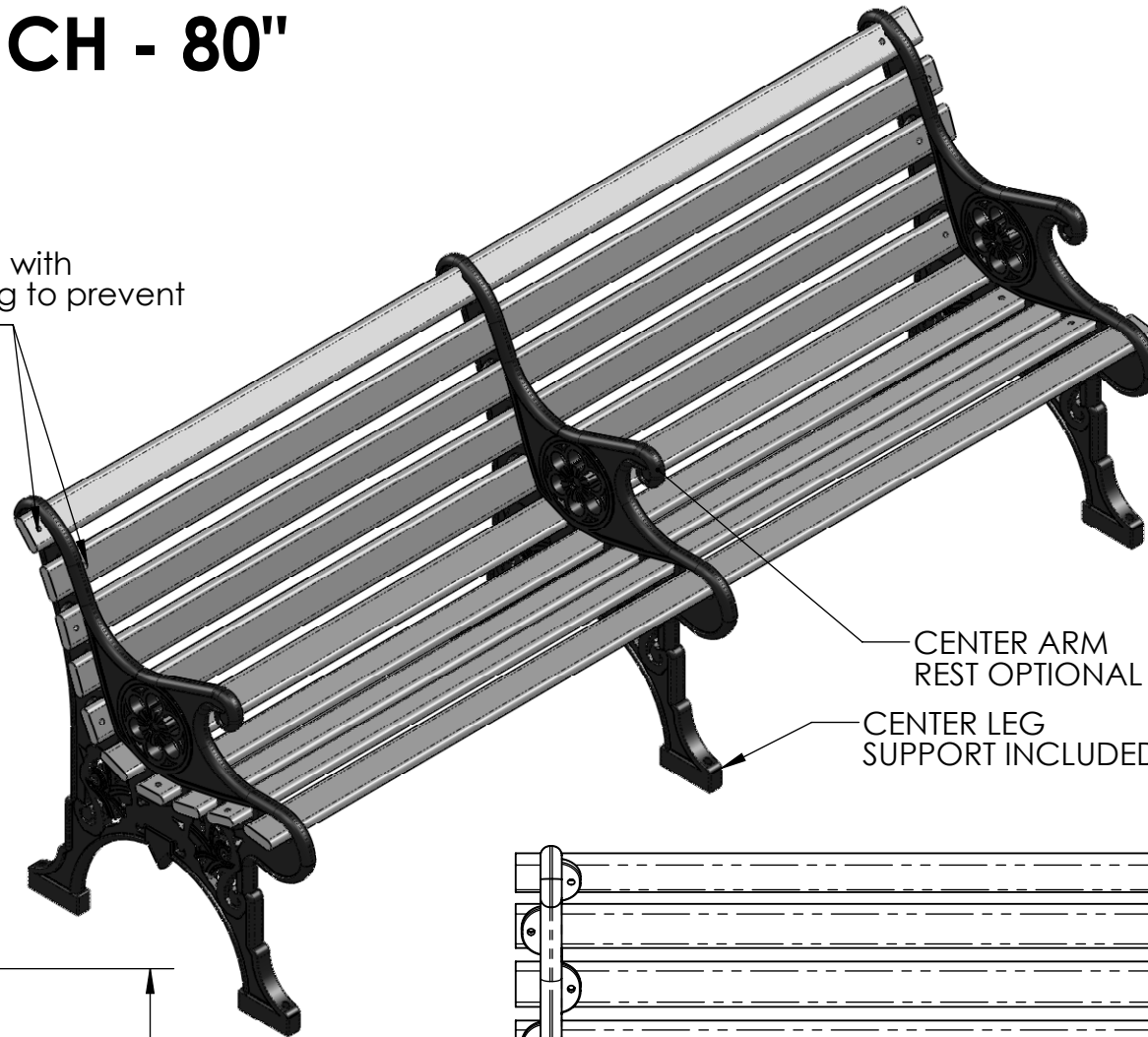

CENTER ARM REST OPTIONAL

CENTER LEG SUPPORT INCLUDED

FRAME

- **Material:** Cast aluminum poured in permanent molds
- **Finish:** Electro static powder coating
- **Color:** Black, White, Green, Tan, Dk. Brown, Dk. Green, Bronze and Blue.

WOOD RAILS

- **Material:** FAS White Oak
- **Size:** 2 1/2" wide by 3/4" milled two edges 3/4" half round
- **Number of Rails:** 10
- **Finish:** PENOFIN® impact impregnated
- **Maintenance:** Apply PENOFIN® as necessary. Follow manufacture's instructions.

HARDWARE

- **Carriage Bolts:** 1/4"-20 steel zinc plate, yellow dipped
- **Nuts:** 1/4" steel zinc plate

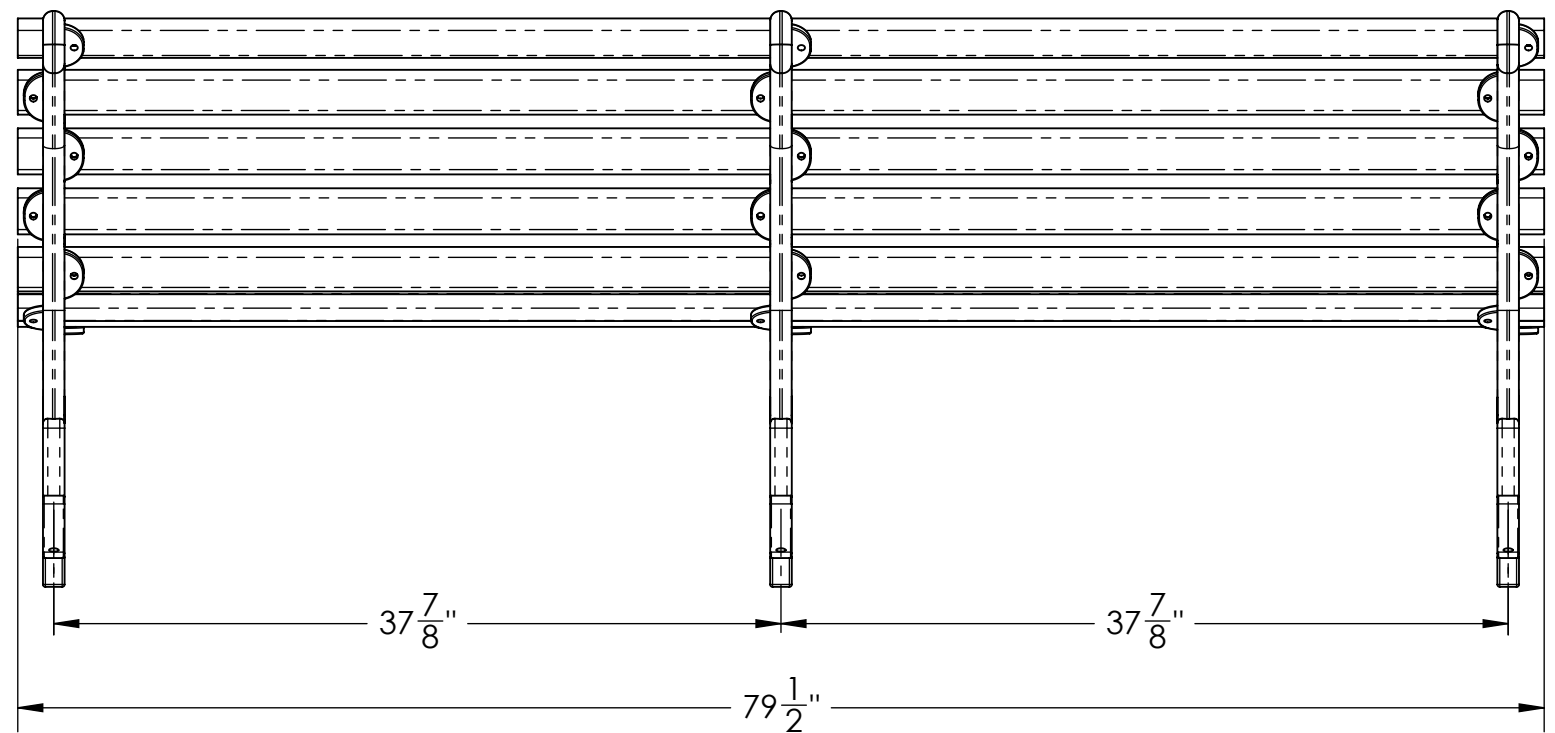
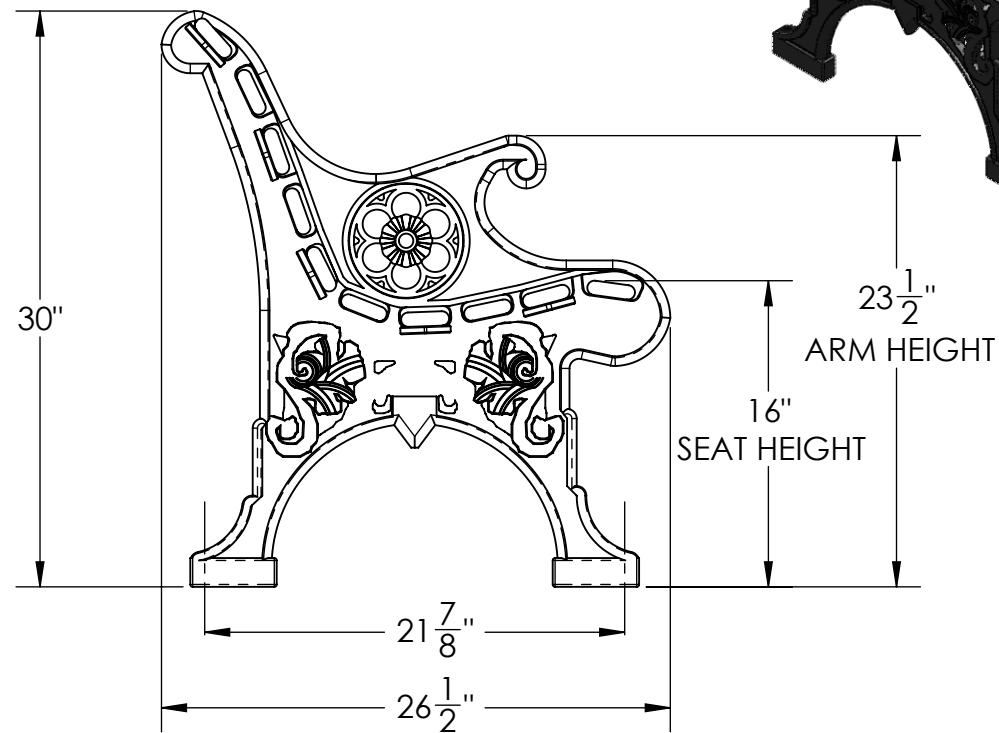

BOLT DOWN DETAIL

VICTORIAN and RENAISSANCE benches can be drilled for permanent attachment.



DESCRIPTION:

RENAISSANCE PARK BENCH - 80"

ADDRESS:
1350 NORTH AVE.
SANGER, CALIFORNIA 93657
PHONE: (559) 875-8250
FAX: (559) 875-1491
kingsrivercasting@verizon.net

THE INFORMATION CONTAINED IN THIS DRAWING IS THE SOLE PROPERTY OF KINGS RIVER CASTING. ANY REPRODUCTION IN PART OR WHOLE WITHOUT THE WRITTEN PERMISSION OF KINGS RIVER CASTING IS PROHIBITED.

WEIGHT: 125 LBS

SCALE: 1:10

MODEL NUMBER:

RBLF - 80"

SIZE

B