

PRODUCT SPECIFICATIONS

RECYCLED PLASTIC PICNIC TABLE 72"

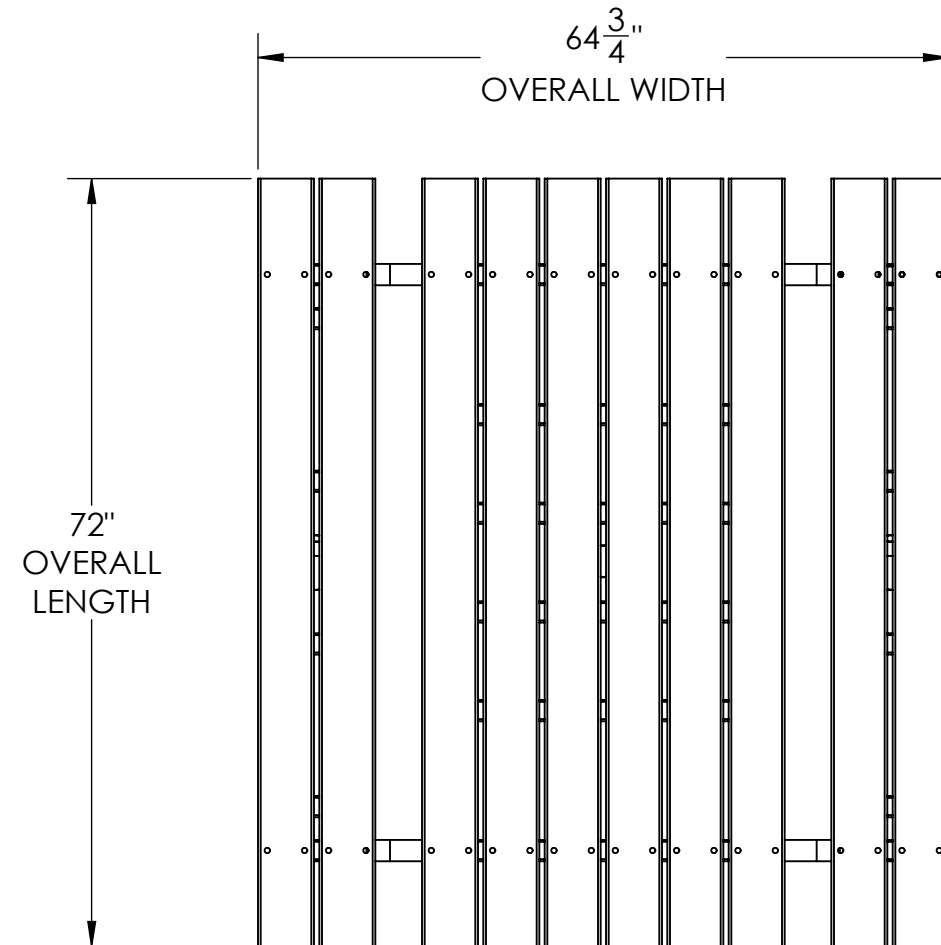

RECYCLED PLASTIC SLATS

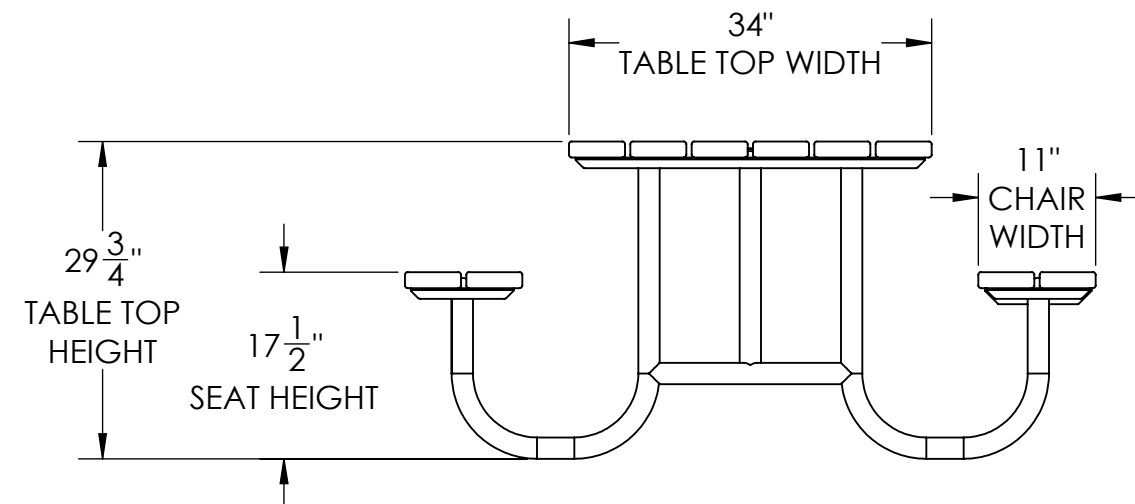
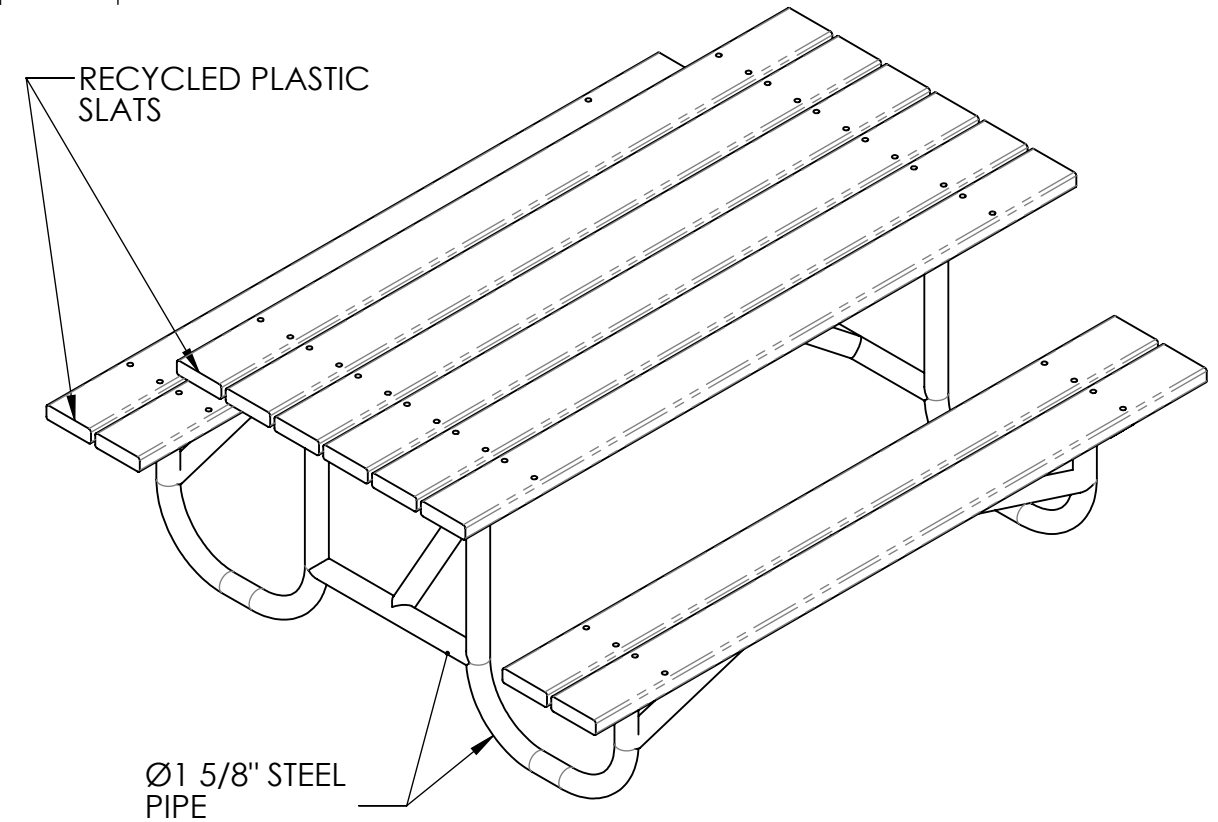
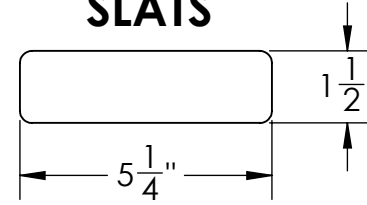

NOTES:

- *SLATS ARE GRAY OR BROWN RECYCLED PLASTIC
- *STANDARD POWDER COATED FRAME COLORS INCLUDE: BLACK, BLUE, WHITE, BROWN, TAN, DARK GREEN, EVERGREEN AND BRONZE.



DESCRIPTION:

RECYCLED PLASTIC PICNIC TABLE 72"

ADDRESS:
1350 NORTH AVE.
SANGER, CALIFORNIA 93657
PHONE: (559) 875-8250
FAX: (559) 875-1491
kingsrivercasting@verizon.net

THE INFORMATION CONTAINED IN THIS DRAWING IS THE SOLE PROPERTY OF KINGS RIVER CASTING. ANY REPRODUCTION IN PART OR WHOLE WITHOUT THE WRITTEN PERMISSION OF KINGS RIVER CASTING IS PROHIBITED.

WEIGHT: 625 LBS

SCALE: 1:18

MODEL NUMBER:

RPPT 72"

SIZE
B