

PRODUCT SPECIFICATIONS

IRON VALLEY SLATTED BENCH - 48"

- All metal fabricated parts are etched, phosphatized, preheated, primer powder coated, and final coat electrostatically powder coated.
- Colors include: Black, Evergreen, Dark Green White, Tan, Dark Brown, and Blue.
- Special order colors available.
- This product can ship either knocked down or assembled.

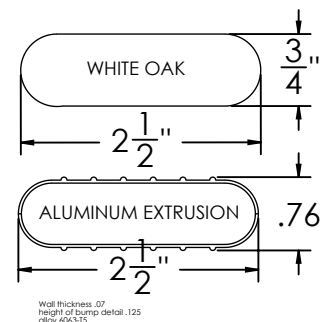

Slats Are Formed From
Astm 1018 Cold
Rolled Steel Bar.
1 1/2" x 3/16"

Hardware:
(6) 1/2" x 2 1/2"
Stainless Steel Flat
Head Bolts

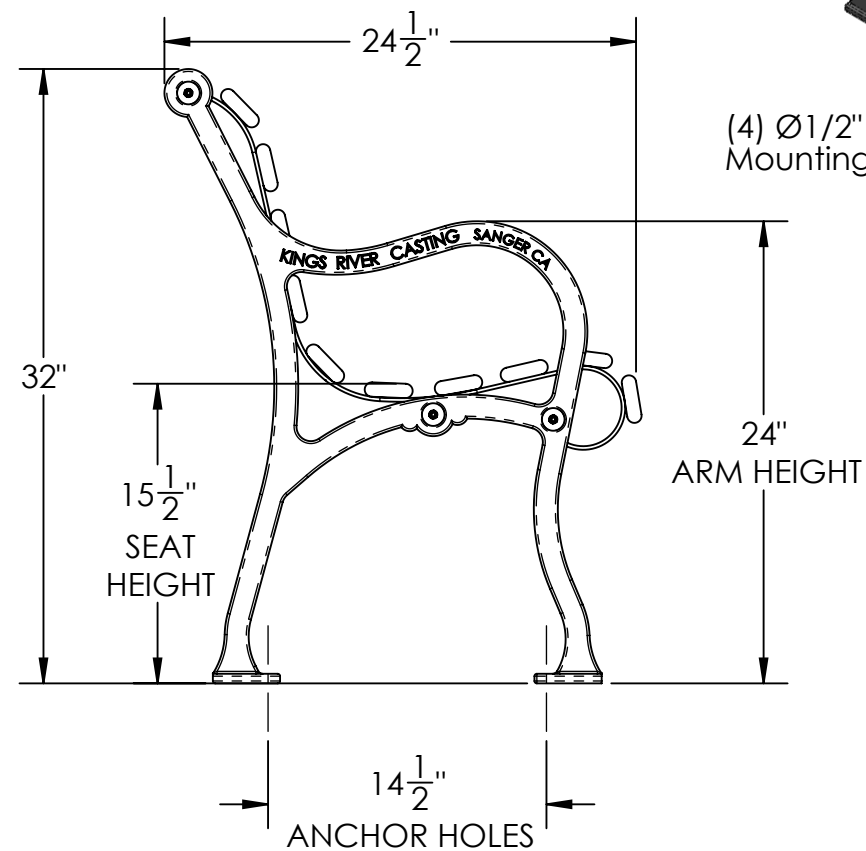
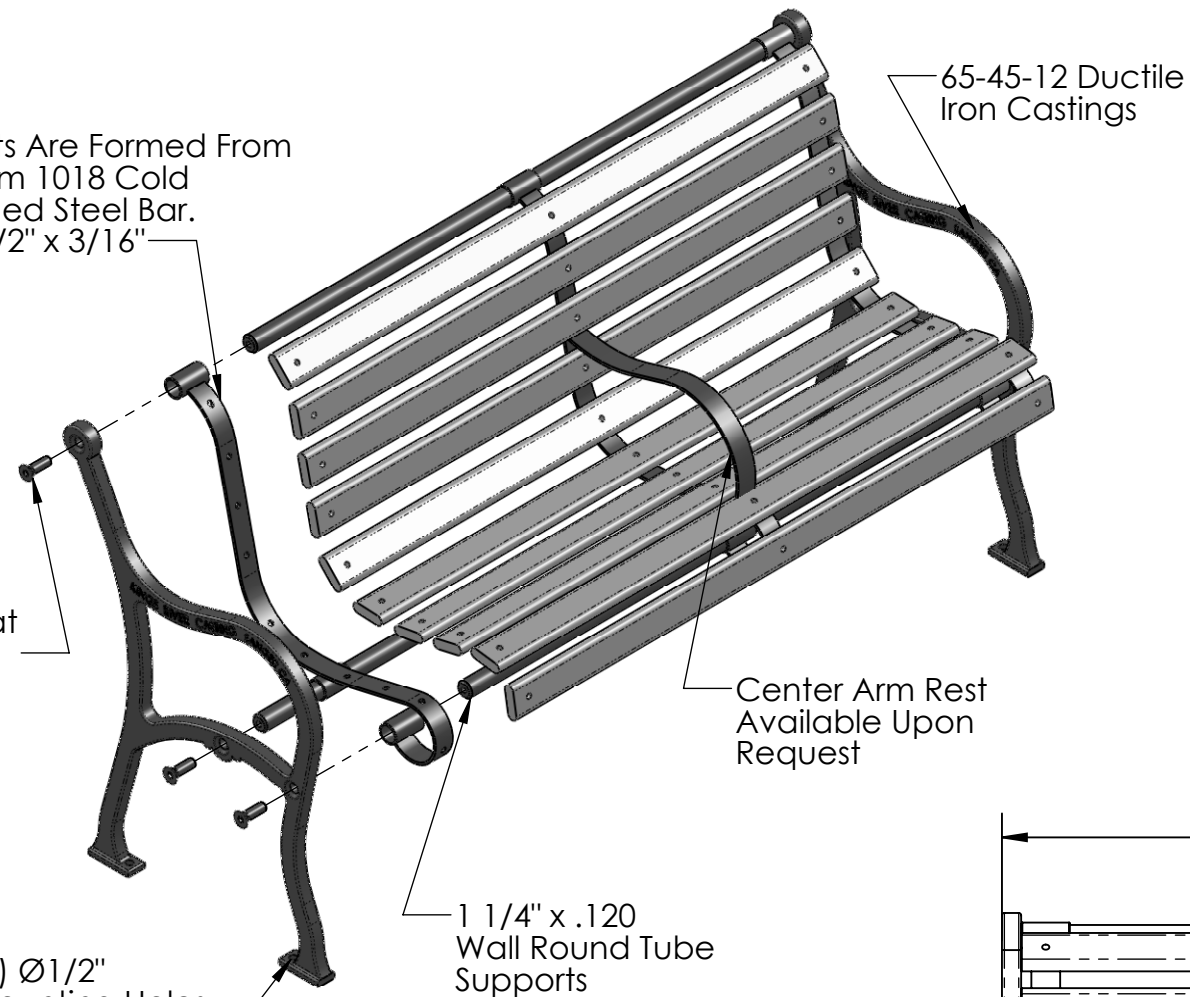

(4) Ø1/2"
Mounting Holes

Center Arm Rest
Available Upon
Request

1 1/4" x .120
Wall Round Tube
Supports

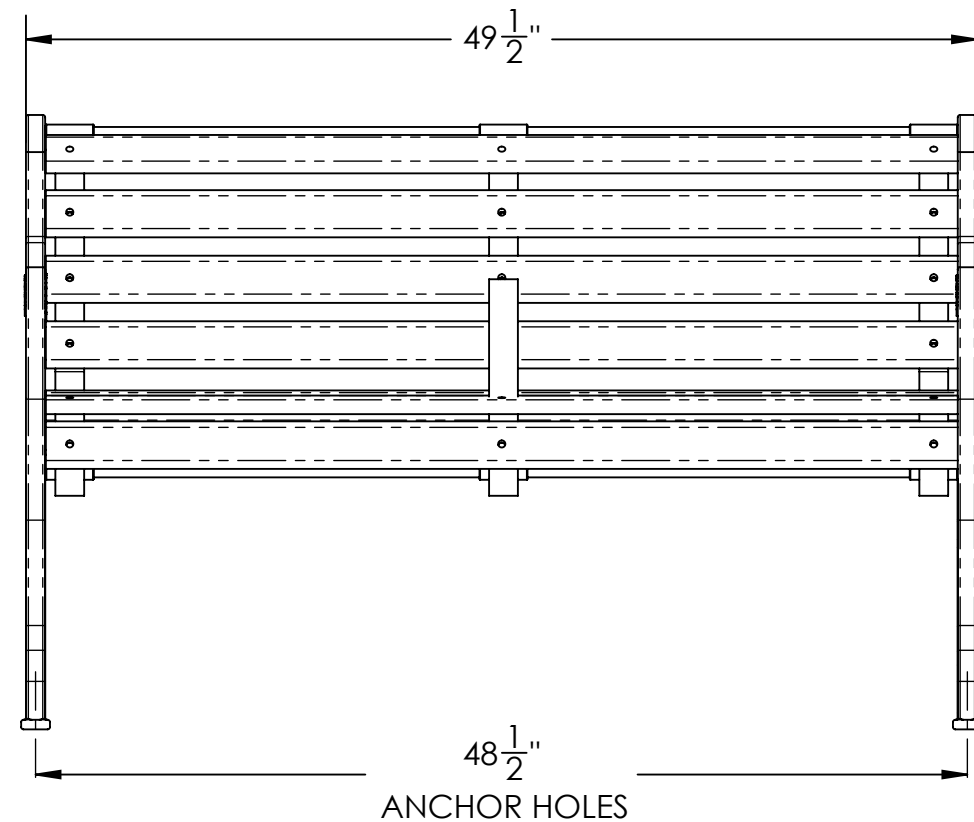

NOTE:

It is not recommended to locate anchor bolts until the bench is in place. Anchor bolts not included.



DESCRIPTION:

IRON VALLEY SLATTED BENCH - 48"

ADDRESS:
1350 NORTH AVE.
SANGER, CALIFORNIA 93657
PHONE: (559) 875-8250
FAX: (559) 875-1491
kingsrivercasting@verizon.net

THE INFORMATION CONTAINED IN THIS DRAWING IS THE SOLE PROPERTY OF KINGS RIVER CASTING. ANY REPRODUCTION IN PART OR WHOLE WITHOUT THE WRITTEN PERMISSION OF KINGS RIVER CASTING IS PROHIBITED.

WEIGHT: 127 LBS
MODEL NUMBER:

SCALE: 1:10

IVSBS - 48"

SIZE
B