

PRODUCT SPECIFICATIONS

CAPITOL BENCH - 80"

ENGINEERED WITH
CROSS-BOLTING TO
PREVENT END PLAY

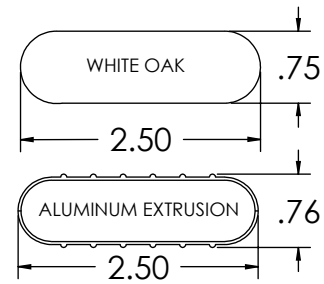

Wall thickness .07
height of bump detail .125
alloy 6063-T5

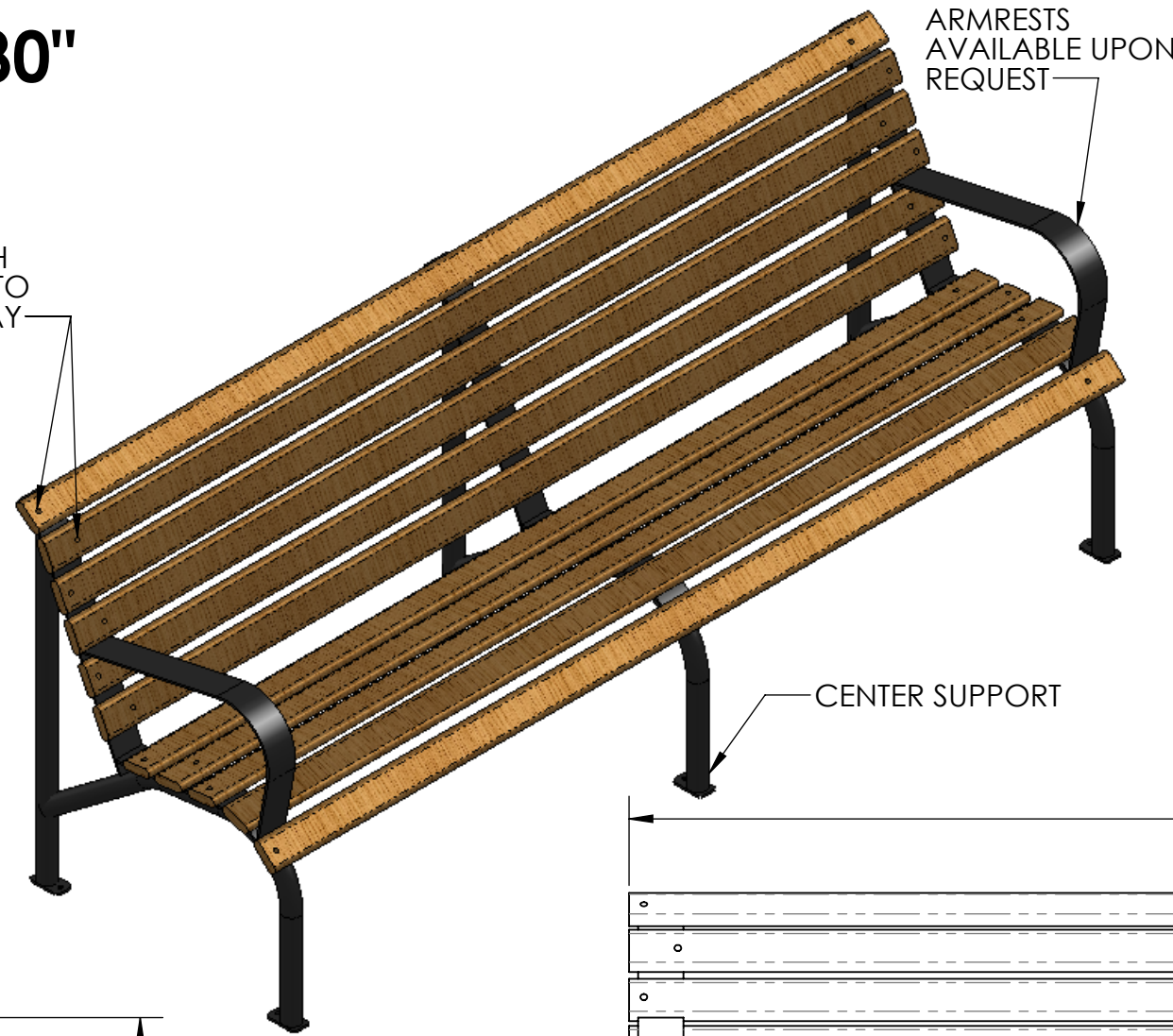

FRAME

- **Material:** 1 3/8" x 1/16" steel pipe and 2 1/2" x 3/16" flat steel.
- **Finish:** Electro static powder coating
- **Color:** Black, White, Green, Tan, Dk. Brown, Dk. Green, Bronze and Blue.

WOOD RAILS

- **Material:** FAS White Oak
- **Size:** 2 1/2" wide by 3/4" milled two edges 3/4" half round
- **Number of Rails:** 11
- **Finish:** PENOFIN® impact impregnated
- **Maintenance:** Apply PENOFIN® as necessary. Follow manufacturer's instructions.

HARDWARE

- **Carriage Bolts:** 1/4"-20 steel zinc plate, yellow dipped
- **Nuts:** 1/4" steel zinc plate

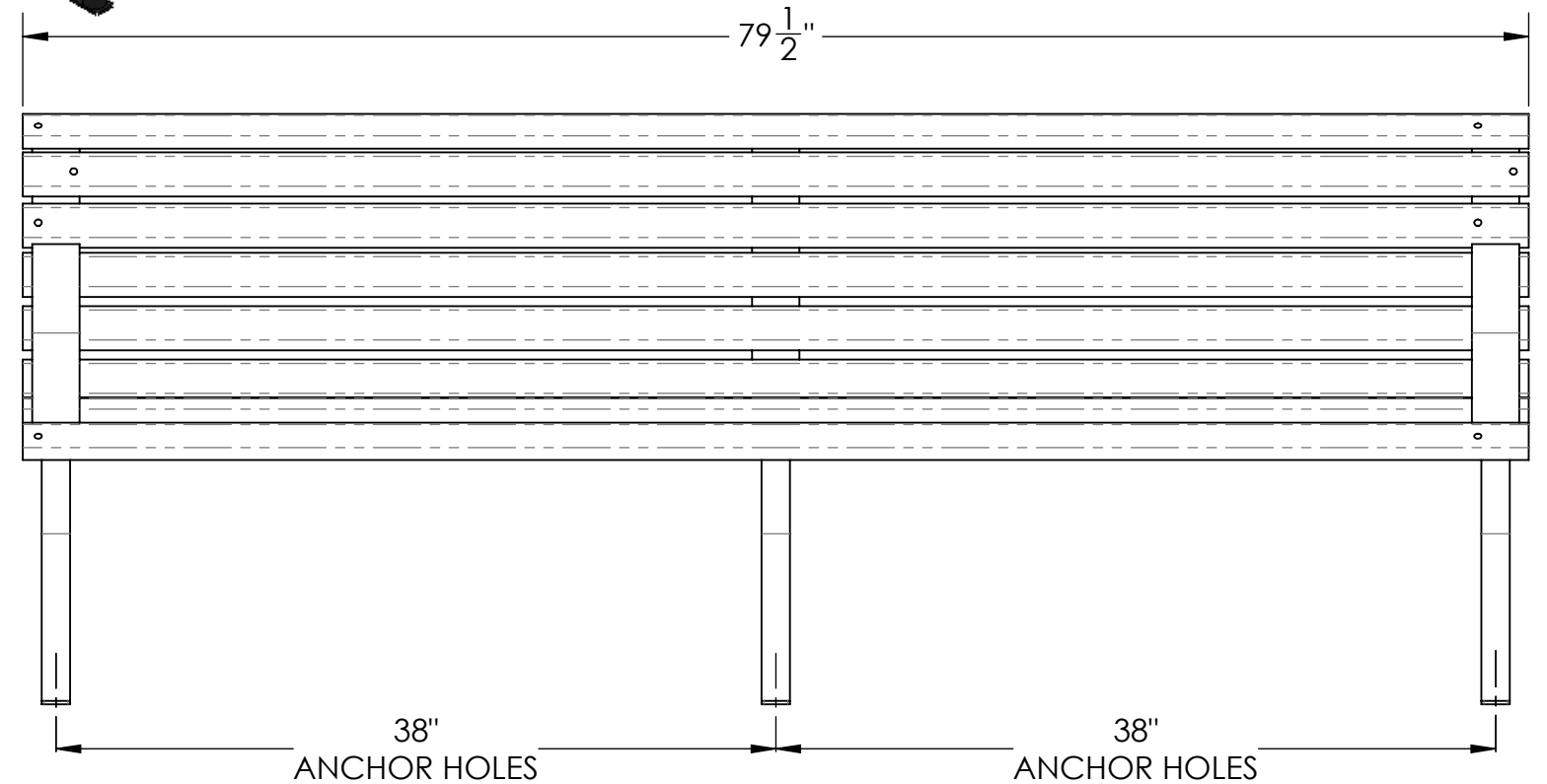
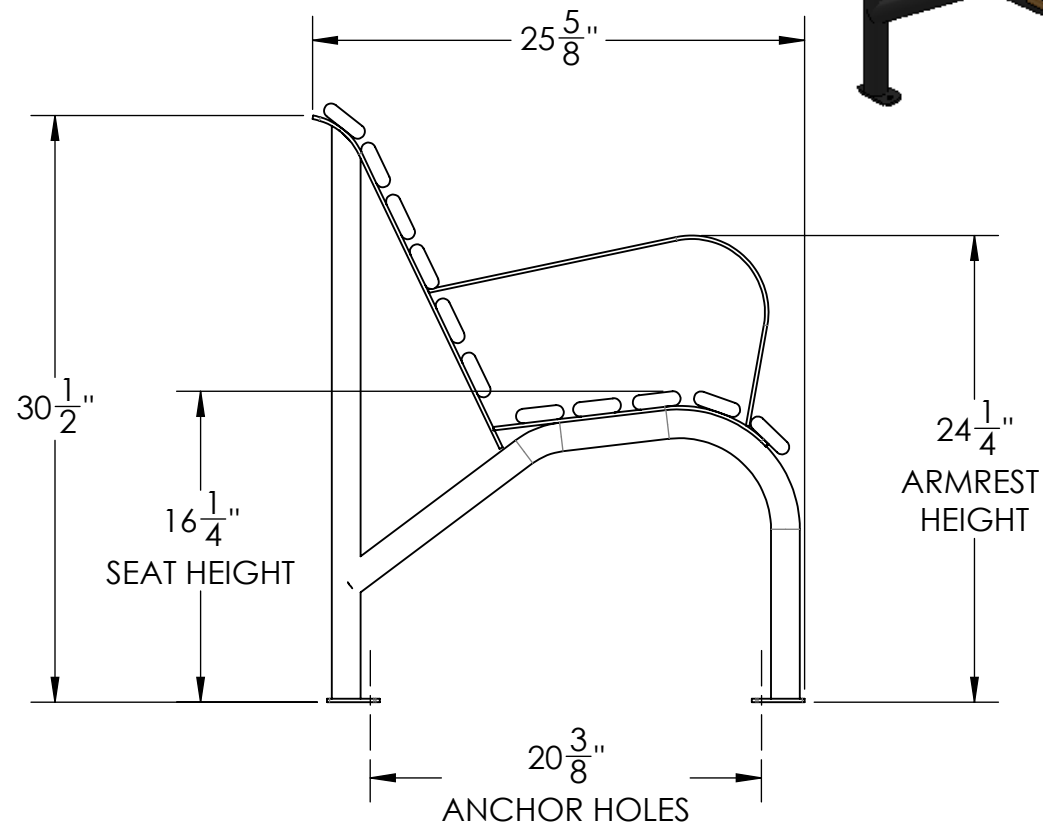

BOLT DOWN DETAIL

CAPITAL benches can be drilled for permanent attachment.



DESCRIPTION:

CAPITOL BENCH - 80"

ADDRESS:
1350 NORTH AVE.
SANGER, CALIFORNIA 93857
PHONE: (559) 875-8250
FAX: (559) 875-1491
kingsrivercasting@verizon.net

THE INFORMATION CONTAINED IN THIS DRAWING IS THE SOLE PROPERTY OF KINGS RIVER CASTING. ANY REPRODUCTION IN PART OR WHOLE WITHOUT THE WRITTEN PERMISSION OF KINGS RIVER CASTING IS PROHIBITED.

WEIGHT: 85 LBS

SCALE: 1:10

MODEL NUMBER:

CBLF - 80"

SIZE

B